

# TEKTRONIX 2465b OSCILLOSCOPE CALIBRATION ISSUES: RE-POWERING THE DALLAS DS1225 or using RAMTRON FRAM or AUTOSTORE RAM or MRAM as DS1225 EMULATORS.

Dr. H. Holden, August 2013.

**UPDATED OCT 2013:** USING 4 PAGE MEMORY BACKUP WITH "PAGE SELECT" - pg 21.

**Updated June 2015:** Equations for Tek Attenuators - pg 27.

[Hugo.holden9@gmail.com](mailto:Hugo.holden9@gmail.com)

## INTRODUCTION:

The Tektronix 2465b oscilloscope requires no introduction for those who have one. It is a fine instrument and has been said to be the last repairable oscilloscope. This is because the scope is supported by a comprehensive service manual with detailed circuits, board layouts and part lists typical of Tektronix instruments made up until the 1990's. Later on, as a worldwide phenomenon, not unique to the Tektronix Company, the new Corporate Model became to rely less on "instrument servicing" and instead give a guaranteed instrument life. In this case if the instrument fails, within the guarantee period, often the whole instrument is replaced, rather than repaired. So less support & documentation is available for field repairs and the new instruments are not set up for easy repairs by technicians either.

THE 2465b:

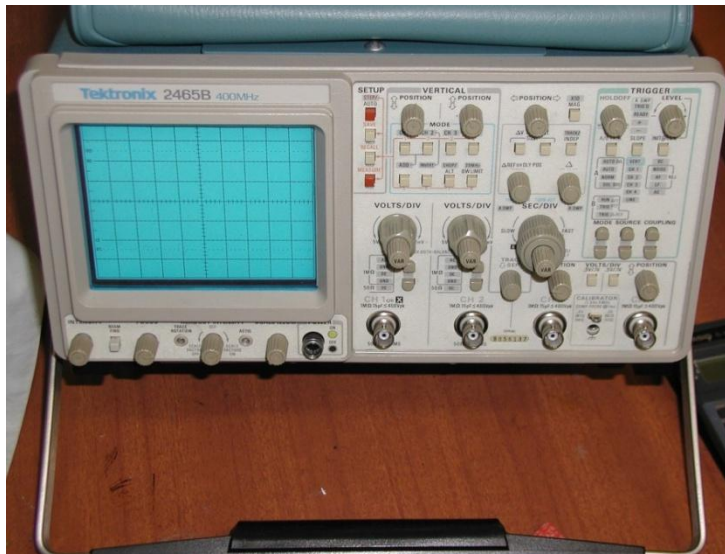

Tektronix laboratory products were so well made that with care and servicing they could possibly last a lifetime. The quality physical implementation of Tektronix designs were matched by the achievements of the Tektronix Electronic Engineers who were obviously masters of circuit design techniques. One can always learn from the circuits they created in their oscilloscopes and other test equipments they created.

When it comes to Oscilloscopes there is something very satisfying about repairing them, especially Tektronix Oscilloscopes.

For those who have inspected the CRT(cathode ray tube) used in the 2465b, it is masterpiece of Electron Optics and outclasses any modern flat panel. However an object like this CRT is much more expensive to manufacture.

#### **FAULT MODES IN THE 2465b:**

The 2465b had a few “time dependent faults” These act as a vector to obsolescence.

Instrument failure creates a situation where the owner has to decide: A) spend more money on a used and aging instrument or B) buy a new one. So any fault in a vintage instrument (> 10 years old) runs the risk of the instrument, which may be generally good, being put on the scrap heap. Which for a high quality instrument is a tragedy and also bad for our planet too.

The first flaw in the 2465b was leaking surface mount electrolytic capacitors on the A5 or digital control board use in the later production 2465b's. After about one decade or more these would leak electrolyte onto the delicate fine pitch pcb tracks and surface mount components. This corrosive material can destroy components, such as surface mount resistors by eating away at the film. Also this ionic & conductive material gets under the components including IC's and creates leakage pathways which disable high impedance circuits. In any event this problem can be remedied by replacing the electrolytics on the A5 board with surface mount Tantalum capacitors and cleaning the pcb, unless the damage is extreme and the board ruined.

As with any aging electronic device, sometimes the 2465b's main power supply electrolytic capacitors need to be replaced also.

Here is a photo of an A5 pcb damaged by the two surface mount electrolytic capacitors leaking down the pcb. It is hard to believe that these capacitors are still in common use. (I hope they have improved the seals)



Electrolytic Capacitors replaced with Tantalum on the A5 board:

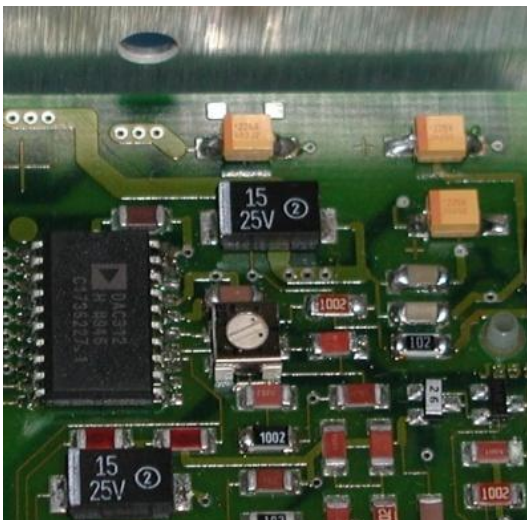

Another common 2465b problem is the IC U800 ran very hot with minimal heat sinking. It is best to add a heat sink to it to preserve it and extend its life. A simple improvement is to attach a heat-sink to its surface as shown below with dual sided adhesive heat conducting sheet and a wire clip to apply pressure. (A better way is a machined heat-sink attached to its metal tab)

**1mm brass wire with heatshrink sleeve  
applies pressure to heatsink against U800**

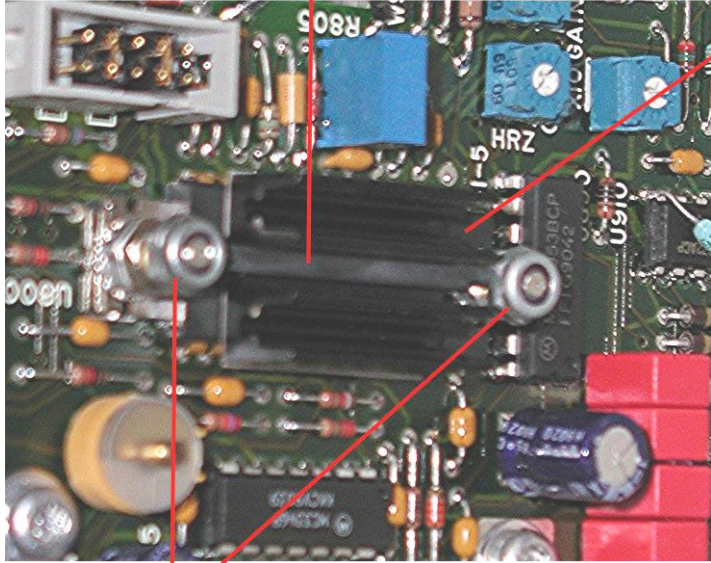

**Heatsink also  
attached to U800  
with double sided  
sticky heat  
transfer sheet**

**Two nuts & washers to retain brass wire clip  
on existing screws.**

The third problem of note for the 2465b, which is the main topic of this article, is the internal battery powered non volatile ram, the DS1225Y. These are another “time clock to failure”. This non volatile ram stores the calibration values for the scope, remembers the scopes last setup and even records the number of hours the scope has run and times switched on & off.

Unfortunately the battery inside this 28 pin modular IC has a limited life. The DS1225Y was also soldered into the A5 board without a socket. The DS1225 was guaranteed to last 10 years, this is nearly the shelf life of the 3v lithium battery. The current drain in standby mode from the two IC's inside the module (scope switched off) is only about 0.2uA or less. Some lithium batteries lasted longer than others. For example I have some DS1225's which are 20 years old and astonishingly they still work. However a test on the internal battery (see how below) on these has shown, as expected, they are on their last legs at that age. Other DS1225's I have lasted 13 years and failed then.

So the DS1225 is “within specification” but it is very inconvenient when it fails as the scope requires a full calibration. If this is the first failure then the DS1225 needs to be removed from the pcb. This is best done with a top quality solder sucker and freeing all the pins except the earth pin 14. Pin 14 can be difficult to clear of solder with a sucker due the thermal inertia of the pcb copper pad there. Then the DS1225 is then removed with the soldering iron applied to pin 14 at the time. A socket is then fitted to the pcb, the suitable socket here is a low profile

dual wipe type rather than round machine pins, these better suit the DS1225 where the pins are relatively thin, flat and fragile.

Once a new DS1225 is fitted, then the scope can be recalibrated.

#### **INTERNAL BATTERY DILEMMA of the DS1225 “BBSRAM” DEVICE:**

The internal batteries of BB (battery backed up) Sram in many of the supposed newer DS1225's are also failing. Despite the battery “freshness seal” in the “AB” versions that protected the battery from discharge until the IC was first powered. The reason for this is that probably the battery's self discharge rate is comparable to the IC's low standby current of about 100nA for the DS1218 and another 50 to 100nA the DS2064 (these are both inside the DS1225 module).

Also, some supposedly new DS1225(AB) versions may in fact be recycled. I came across some new looking ones sold as new with data already in them and leads that had been soldered to before. In any case, once the scope is calibrated and there is a replacement DS1225 in a socket, it is reassuring, because it is all working.....but again it won't last, all the calibration data will be lost when the battery in the DS1225 discharges.

#### **SOLUTIONS TO THE PROBLEM OF DISCHARGED BATTERIES:**

One method is to accept they do fail and simply remove the DS1225 from its socket as soon as the scope is calibrated and place it in a ram reader/writer. The one I use is the GQ-4X universal programmer from MCUmall Electronics in Canada. Read the DS1225 and save it to a file labeled as the scope's serial number and return the DS1225 to the scope. That way when the DS1225 inevitably fails you can program another DS1225 right away and fit it, without the need to recalibrate the scope. However I think there is something wrong with having to throw away a DS1225 with good IC's inside it and merely a flat battery.

The other method is to attempt to give the DS1225 “immortality” by gaining access to its internal battery connection and paralleling an additional lithium battery. Firstly it is interesting to look inside the DS1225:

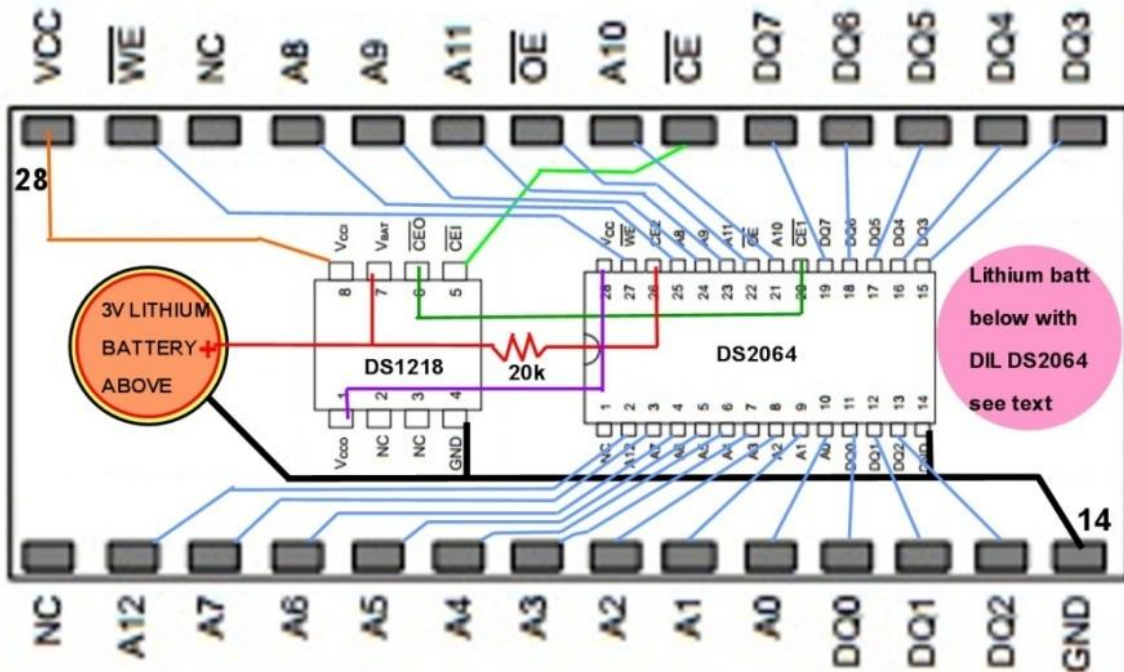

## INSIDE THE DALLAS DS1225(AB) + 70 nvRAM.

The DS1225 is merely a standard DS2064 Sram combined with the DS1218 battery controller IC and the lithium battery. Different DS1225 modules have the batteries in different places.

The DS1218 holds both pin 28 (Vcc) and pin 20 (/CE) of the DS2064 Sram IC at the battery potential (around 3v) when the 5V power is off. This saves the data in the DS2064 Sram and write protects it regardless of the voltages on /CE and /WE pins. In addition notice how pin 26 of the DS2064 IC is held at the battery voltage via a 20k resistor. One consequence of a flat battery is that pin 26 of the internal DS2064 falls low, which causes the DS1225 module to malfunction even when powered by the external 5 volt supply. So when the battery is low, the DS1225 won't work in the scope or a ram reader/writer for that matter even with an external 5V supply on pin 28 or VCC. The GQ-4X reader/writer reports "Write Fail" 0x00003A buffer 0x00 Device 0xFF if you try to write the DS1225 with a flat battery (or a DS2064) for that matter with a low on pin 26 (CE2).

When the battery gets into a marginal condition around 1.8 volts, the DS1225 still will retain its memory but it won't read or write in a reader/writer. If the battery supply voltage is brought up to 3V it will start to function again. With a very flat battery the data is lost too. So the

read/write functions fail before the data in memory gets corrupted as the battery is going flat, but ultimately, it is all lost.

Most types of the DS1225Y such as DS1225AB 85 and 150 and 200 suffix types contain the 28 pin DIL DS2064 Sram which occupies most of the space in the module and sits just below the top surface of the module's body. The IC's pins are soldered to the top of a thin PCB adapter board. On the board's lower surface are placed the lithium battery at one end and the DS1218 IC at the other end, all potted in black resin. The battery sits between about pin 12 and pin 17 at the mid-point and the battery's edge is about 5 to 6mm from the short side of the case.

Looking at the resin in the bottom of the DS1225 module it is often possible to see the round outline of the battery and its flat terminal which connects to the ground pin 14. This is not wonderful as it is the battery's negative terminal that is close to the surface, we need a connection to the positive terminal. (The negative terminal is already available on pin 14).

All is not lost because as noted in the diagram, the battery positive also connects to pin 7 of the DS1218 and it is easy to gain access to this by removing a small amount of resin beside the pin. The photos below show an "experimental resurrected DS1225Y" with a temporary added battery. This brought the DS1225Y back to normal operation:



There is a different version of the internal anatomy found in the +70 variants of the DS1225AB. In this unit the IC within is a 28pin SOIC type not a large DIL type. There is much more room in this module so the battery was relocated to the **upper surface** of the pcb in this module. In addition the battery positive terminal faces upwards & outwards and it is only about 1mm to 1.5 mm below the surface. A 4.5mm area of plastic is cut away with a milling tool or a near flat end drill also works with care:

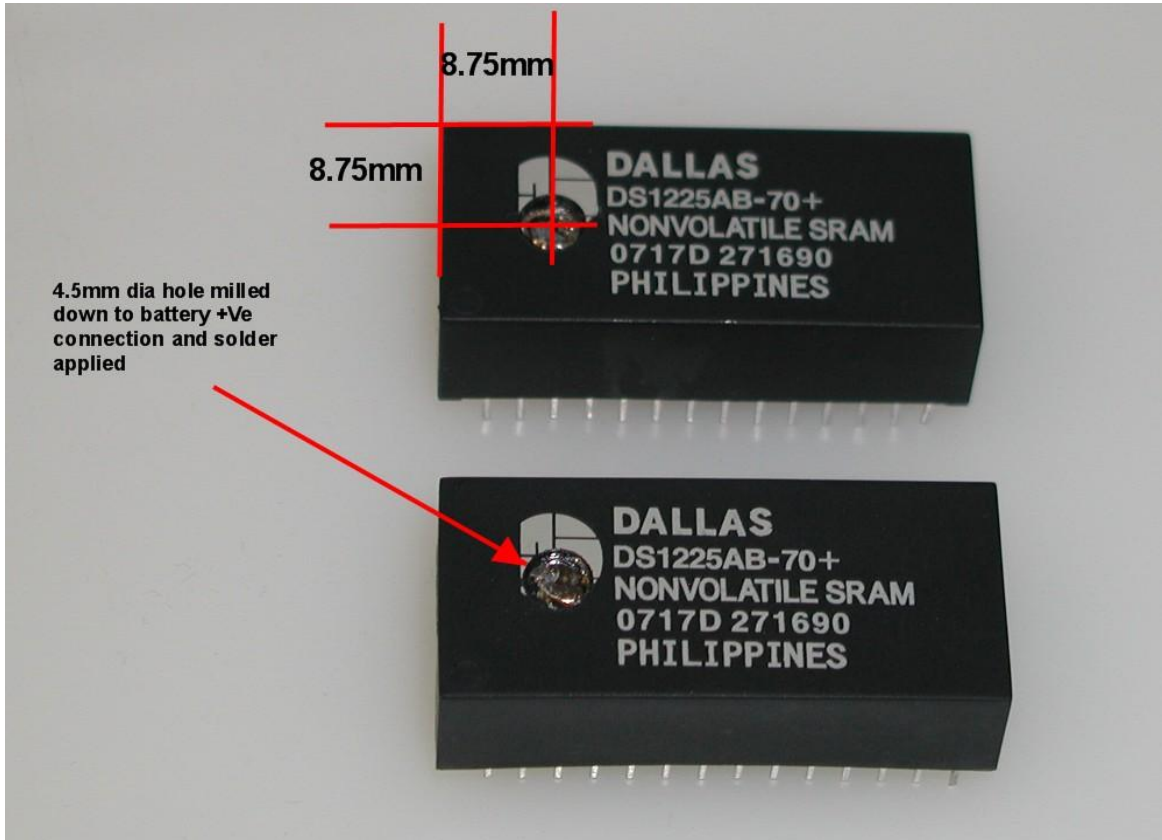

The positive battery terminal is very easy soldered to without excessive heating. (The actual terminal or tag is spot welded to the battery surface by small spot welds).The solder is added to be just above the height of the IC top surface. A CR2032VC battery (Jaycar part SB1762) has its pins cropped and the positive battery terminal plate is tinned in the area it attaches and is soldered to the solder lake. This gives a very strong attachment for the added battery and avoids one wire. I also used some very thin double sided tape between the battery and the IC top surface, but it probably wasn't necessary.



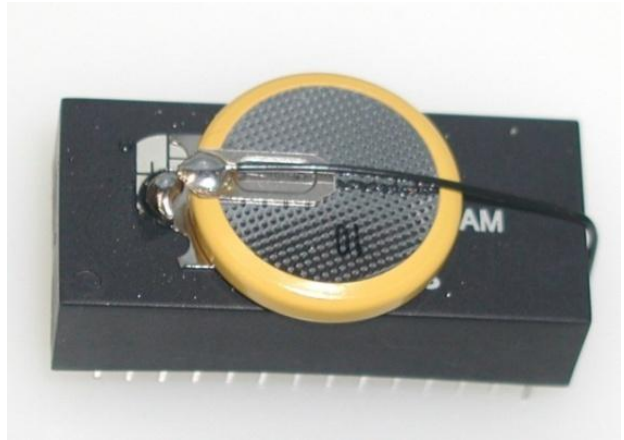

A piece of wire wrap wire is use to connect the battery negative terminal to pin 14 of the DS1225 module at the very base of the pin so it does not interfere with it plugging into a socket:

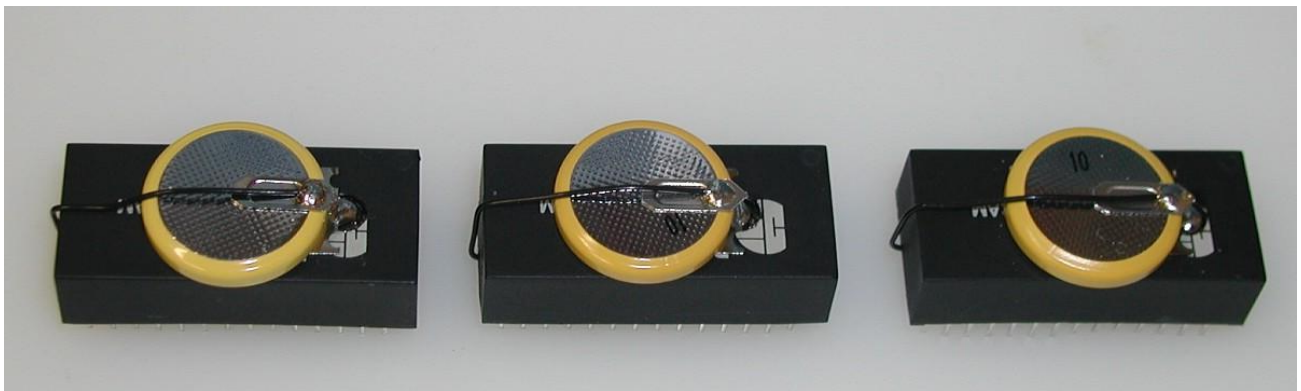

It is always worth labeling the DS1225 BBSRAMs with the scope's serial number so they don't get mixed up if you program them & remove them and you have more than one scope. One

advantage of this method is that strictly speaking, although lithium cells are not rechargeable, even discharged ones tend to charge up a little with applied voltage from a paralleled battery and therefore, when the added cell is replaced, perhaps every 8 years, the internal battery allows the IC's hold the data more than long enough for a battery change.

**Unfortunately with the method shown above, for use in a 2465b scope, there is only enough room to do this if the DS1225 is NOT in a socket.**

This is because the height of the socket + the DS1225 + the battery thickness is such that it is just touching the inside surface of the scope's housing. It is at ground potential but this is not ideal. It is really better to have a socket too. So another option is to simply connect a wire to the top of the DS1225 with a connector pin and place the battery elsewhere. This has the advantage that a large high capacity lithium battery can be used:

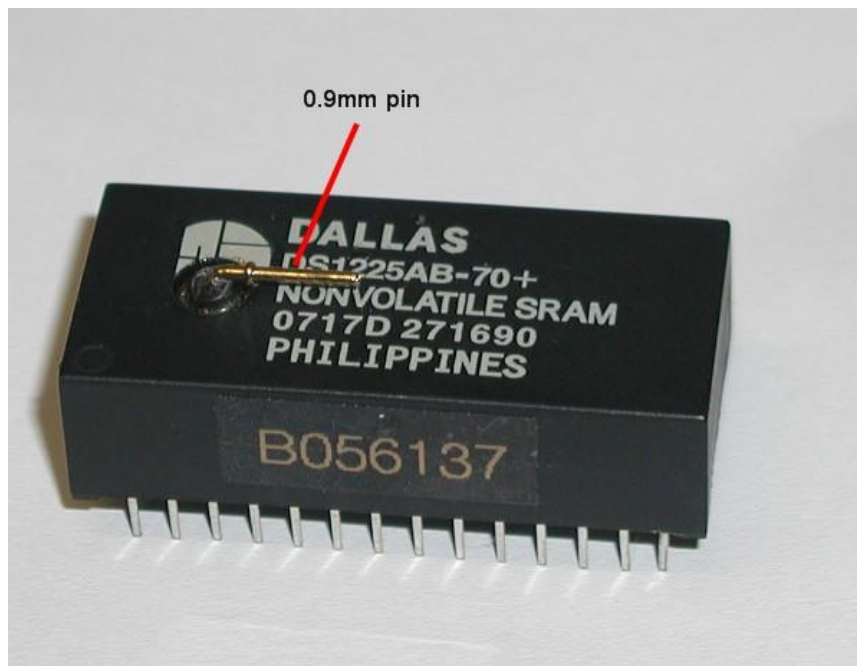

In this instance an AA sized or 1/2AA sized lithium battery can be placed in the spare space in the scope chassis near the right hand end of the A5 pcb. If you do this, place 5K to 10k resistor in series with the battery positive wire as the wire might inadvertently touch part of the A5 circuit board before its plugged onto the 0.9mm pin attached to the DS1225AB-70+ BBSRAM.

## What is the consequence of paralleling a new battery with a discharged one?

Of the three DS1225AB +70 modules above; one had a reasonable internal battery initially measuring close to 3V. The other two units had battery voltages of 0.5V. Initially, on connecting it up and placing a 50uA fsd meter in series with the negative wire of the added battery, the current was about 20uA. A day later the unit which had the reasonable internal battery to start with had a current drain of less than 1uA. (In theory it should be about 0.2uA) some of this is internal battery leakage current. The other two units had dropped to 7uA each.

The CR2032 has an approx 0.23Ahr capacity, so with 1uA drain the life would be 26 years, well in excess of the battery shelf life. With 7uA drain it would only be about 3.7 years. The 7uA value may fall with time, **but this test probably demonstrates that it is better to apply the external battery when the internal one is still in reasonable condition.** An AA sized or ½ AA sized lithium battery is a much higher capacity than a CR2032 and would last for their shelf life, I'd expect 15 perhaps 20 years.

In general it appears that some memory areas of the DS1225 are not used in this 2465b oscilloscope application. There is a sector of memory from address 08F0h to 0930h that always appears as hex FF and unused. Therefore it is possible to use some of this "empty space" up by writing into it manually with the programmer with a few lines of hex to translate to ASCII characters to note when the calibration was performed who did it and the scope's serial number as shown:

```
00000880 0B 58 05 03 0B 62 00 00-2A 56 00 00 A0 A0 A0 A0 .X...b..*v.....
00000890 17 54 00 FA 39 FA 37 00-00 00 01 A0 A0 A0 A0 .T..9.7.....
000008A0 A0 FF 63 9B CB FF 5C FF-62 A0 A0 FF 61 FF 51 A0 ..c...\b...a.Q.
000008B0 A0 A0 A0 A0 A0 A0 A0 FF-5E FF 5D A0 F8 55 00 4C .....^.]..U.L
000008C0 FF 00 63 ED 4F FF F7 A0-A0 A0 00 92 AC BC D4 B8 ..c.O.....
000008D0 C8 BC FF FF FF FF FF FF-FF FF FF FF FF FF FF FF .....
000008E0 FF FF FF FF FF FF FF FF-FF FF FF FF FF FF FF FF .....
000008F0 32 34 36 35 62 FF FF FF-FF FF FF FF FF FF FF FF 2465b.....
00000900 48 75 67 6F 00 48 6F 6C-64 65 6E FF FF FF FF FF Hugo.Holten.....
00000910 43 41 4C 49 42 52 41 54-45 44 FF FF FF FF FF FF FF CALIBRATED.....
00000920 41 75 67 75 73 74 00 00-32 30 31 33 FF FF FF FF FF August..2013....
00000930 53 2F 4E 00 42 30 35 31-37 32 33 FF FF FF FF FF S/N.B051723.....
00000940 FF FF FF FF FF FF FF FF-FF FF FF FF FF FF FF FF .....
00000950 FF FF FF FF FF FF FF FF-FF FF FF FF FF FF FF FF .....
00000960 00 92 AC BC D4 B8 C8 BC-FF FF FF FF FF FF FF FF .....
00000970 FF FF FF FF FF FF FF FF-FF FF FF FF FF FF FF FF .....
00000980 FF FF FF FF FF FF FF FF-FF FF FF FF FF FF FF FF .....
00000990 FF FF FF FF FF FF FF FF-FF FF FF FF FF FF FF FF .....
000009A0 FF FF FF FF FF FF FF FF-FF FF FF FF FF FF FF FF .....
000009B0 FF FF FF FF FF FF FF FF-FF FF FF FF FF FF FF FF .....
000009C0 FF FF FF FF FF FF FF FF-FF FF FF FF FF FF FF FF .....
000009D0 FF FF FF FF FF FF FF FF-FF FF FF FF FF FF FF FF .....
000009E0 FF FF FF FF FF FF FF FF-FF FF FF FF FF FF FF FF .....
```

This “label” is also useful looking at ram images later and trying to recall what scope it belonged to and puts a unique identity into the RAM. Also if the ram data gets corrupted later it will likely be easy to see that on a read, rather than looking for changes in hex numbers. (For example when rams are checked for radiation resistance it is done by programming them with a checker-board pattern so data corruption is easy to spot). Putting some data in here does not appear to alter the calibration or function of the scope.

## REPLACING THE DALLAS DS1225 64Kb nvRam WITH ALTERNATIVE NON-VOLATILE RAMS:

### A) THE FERROELECTRIC NON-VOLATILE RAM

The Ramtron Fram part FM1608 is an 8k x 8(byte) = 64Kb(bit) non volatile ferroelectric ram, it requires no battery. An internet search on the topic of using Fram to replace Sram revealed that the general view posted on forums was that this would not work. The concern was that the read mode required /CE to be asserted to validate each new address because in the FM1608 the input data is latched on the falling edge of /CE, therefore if /CE was not asserted for each read, the FM1608 would not work as a direct substitute for BBSram. This difference is shown in the diagram below:

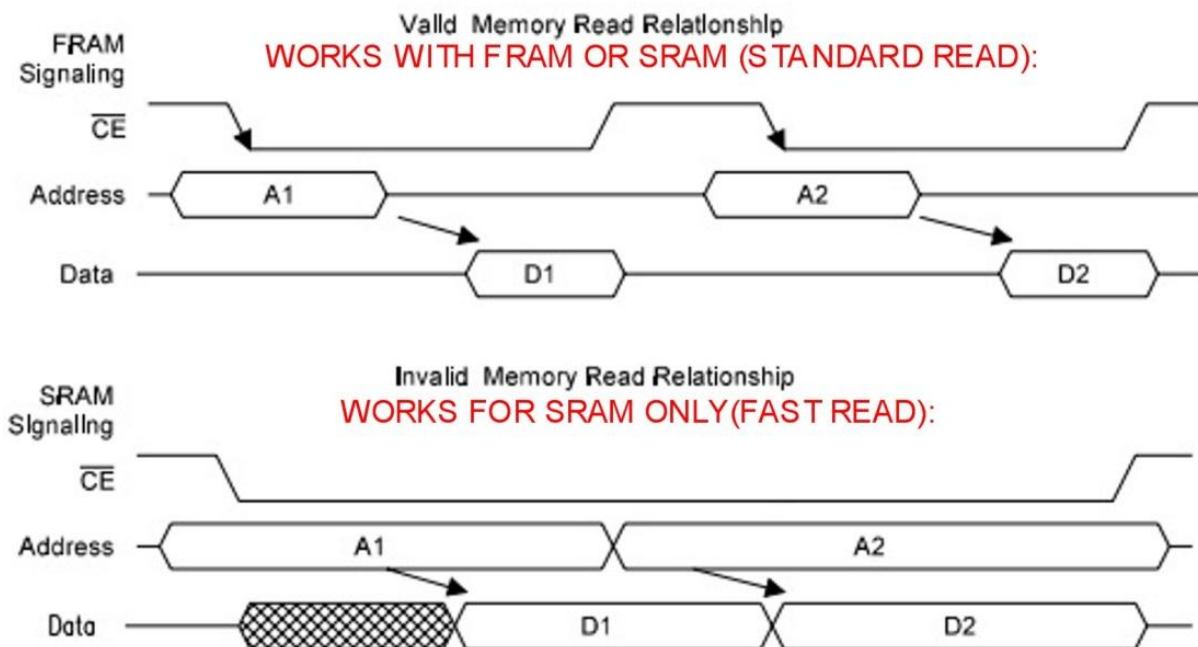

It is therefore possible to hold /CE low in the Sram while the addresses are changing and valid data is available at the output. However in any system where there is alternate reading & writing happening this would not be the usual way to use the Sram memory unless a very fast read mode was required, presumably for something like a video application. In the standard read/write mode, /CE is asserted low during both the read and write cycles.

On the write cycle side of things, both the DS1225 and the FM1608 have either /WE or /CE controlled writes (in which one can go low before the other) which are not dissimilar.

To test the theory out that an FM1608 would (or would not) work, initially a FM1608 IC was placed in the GQ-4X Universal IC programmer. The FM1608 is “not supported” by this programmer, so the programmer was set for a DS1225Y. Writing to the FM1608 and reading from it occurred without any difficulty and it perfectly emulated the DS1225. Then the FM1608 was programmed with the image of a DS1225 removed from a calibrated 2465b. The FM1608 was removed from the programmer, left for a time and placed back in the programmer and read. A perfect result was obtained with correct retained data. The FM1608 was then placed directly into the DS1225 socket of the A5 board on the 2465b scope. On checking the scope behavior and calibration was perfectly normal. The scope remembers its control settings and appears to have no difficulty reading or writing to the FM1608 Fram and passes all self tests and remains in correct calibration.

The /CE and /WE pins were scoped while the Fram was in the 2465b:

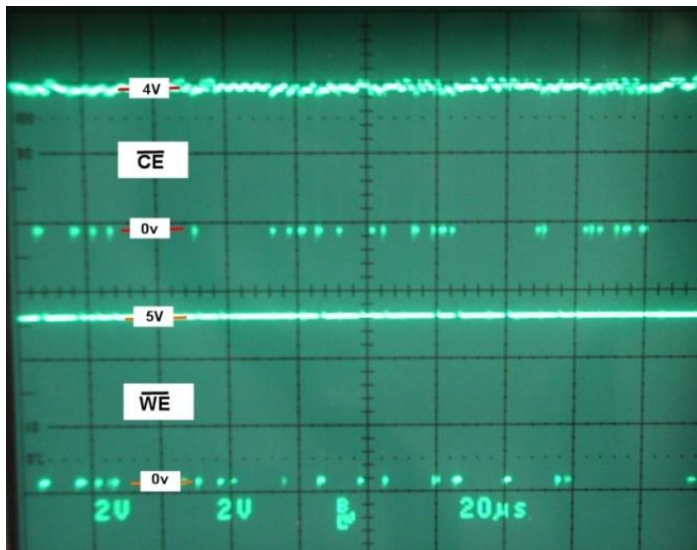

The /CE pin is very active, not held low for any continuous period. Curiously it was noted that occasionally /WE falls low while /CE is high and this would make no difference to either an

FM1608 or a DS1225. Most of the /WE low assertions are associated with a /CE low and at other times /CE is low only while /WE is high during a read. The photo below shows the FM1608 working normally, emulating a DS1225Y in a 2465b scope:

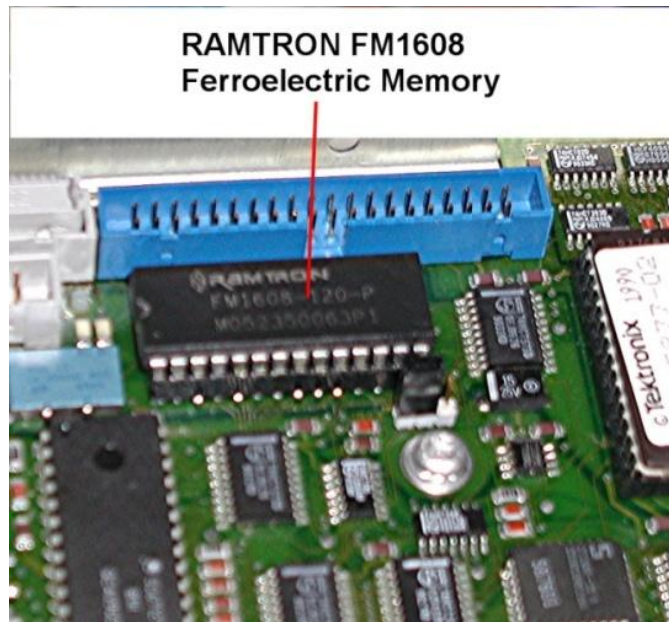

So it appears that the addressing mode in the 2465b is a standard (not fast) mode and this is perfectly compatible with either Sram or Fram.

From the scope trace there are about 4 to 5 writes in 44 us so the write rate is roughly about 100KHz. If the FM1608 was used to be a substitute for a DS1225Y it raises the interesting question how long it would last, on the basis that the FM1608 is rated for  $10^{12}$  access cycles. Constantly changing the polarity of the ferroelectric cell fatigues it, in that the remanent charge of the ferroelectric capacitor dipoles could, with enough time and cycling, fall below the detectable level.

The atomic structure of a ferroelectric element allows it to have a bi-stable state where the polarity of the structure can reverse under an applied voltage field. When the field is removed it stays in the final state. This is due to the mobility of either Titanium or Zirconium atoms in the crystal lattice which is a cage surrounded by oxygen and lead atoms:

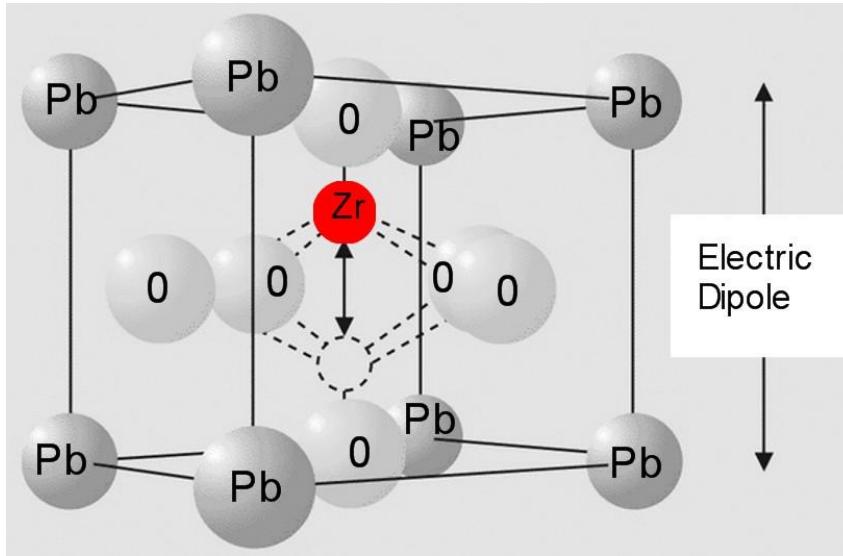

Curiously the original FM1608 was rated at only  $10^{10}$  cycles in the original Ramtron year 2000 data sheet. Later by 2007 Ramtron upgraded the data sheet to  $10^{12}$ , however it is not clear at all if the IC itself was changed for this parameter, or just the data sheet! One possible explanation is that the actual endurance is very dependent on the supply voltage. A Texas Instruments paper, relating to their Frams, suggested a change in supply voltage by as much as 0.1v could affect endurance by a factor of 10. The following graph was taken from a Ramtron article:

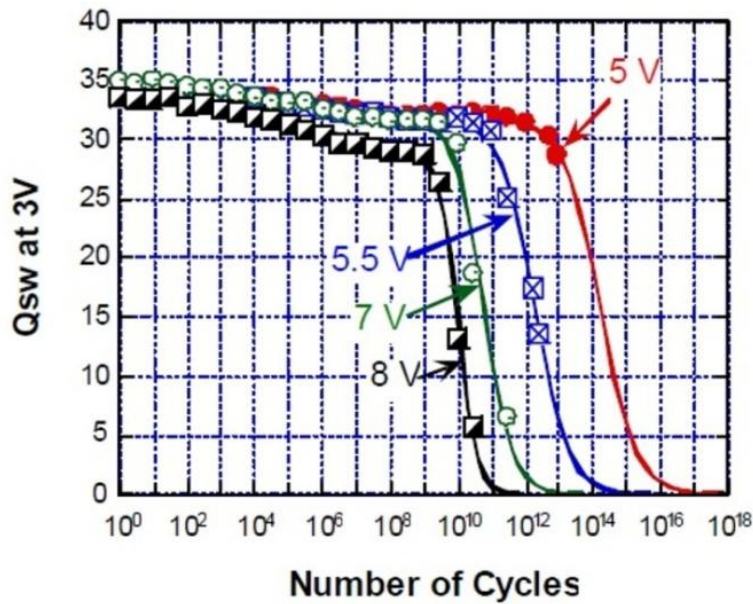

**Figure 1.  $Q_{sw}$  vs. Endurance Cycles shows fatigue is accelerated at higher applied voltages**

The endurance is measured by the  $Q_{sw}$  value. This is the switched charged density which is equal to  $2Pr$ , where  $Pr$  is the remanent polarization of the ferroelectric capacitors which are the basic storage unit inside the Fram. These molecular units alter their polarization after an applied electric field and have an “electrical hysteresis loop” which is similar in shape to the magnetic B - H style hysteresis loop of flux density and magnetizing force except for the Fram it is remanent charge and electric force. So these FRAM IC’s are in fact analogous to an “electrostatic version” of the old fashioned hand woven “magnetic core memory”. They also have the same property that reads are destructive to data if the electric dipoles flip during the read, and need to be re-written to restore them.

$Q_{sw}$  has units of  $\mu C/cm^2$  (micro Coulombs per square centimeter) and as shown from the graph above the endurance is 2 orders of magnitude better at 5V supply voltage than it is at 5.5V, so perhaps the original  $10^{10}$  cycle specification was for the worst case (highest) supply voltage of 5.5V and not 5V for the FM1608. When the  $Q_{sw}$  value falls after long periods of read/writes to below  $6 \mu C/cm^2$  there may not be enough residual charge in the ferroelectric capacitor dipoles for the memory to read & write reliably and the Fram will be failing.

*(On the other hand, in the case of a DS1225, the battery is discharging primarily when the instrument is turned off and powering the internal DS2064 and DS1218 IC’s, however the lithium battery has internal self leakage and discharges itself over a long time frame. In any event a lithium battery can only be regarded as reliable for 10 years and perhaps a bit longer due to the fact the scope is being used a percentage of the time. And that is starting with a brand new lithium battery, which in the case of actual DS1225 modules can barely be guaranteed).*

The data retention in the FM1608 is 45 years and the FM1608 is rated to perform at an access rate of 3KHz for 10 years, which is 87600 hrs. (Clocking at 100KHz this would correspond to about 2777 hours) *However this is read/writing the same row of the memory’s architecture.*

The memory is divided into rows & columns and each read (or write) access causes an endurance cycle for an entire row. Each row is 32 bits wide (4 Bytes) and there are 256 rows making 1024 bytes along the rows in total which are set up in 8 columns or blocks. So if the memory locations were either sequentially exercised by stepping through the addresses one by one or randomly selected, each row would only be selected  $1/256$  of the time raising the overall endurance of the IC to about  $2777 \times 256 = 710912$  hours or close to 81 years with the scope powered 24/7. But for this 2465b application it is not known what the exact maximum read/write rate is for *one single row*, only the overall rate is known. However this suggests that the endurance time would be probably be comparable to the data retention time of 45 years. So it would appear that the basic FM1608 Fram longevity is very satisfactory for a 2465b.



The FM16W08 is a similar Fram, however astonishingly it is rated for  $10^{14}$  cycles, or two orders of magnitude better than the FM1608. This appears to have been partly achieved by eliminating the 8 block architecture in the FM1608 and simply having the memory in 1024 rows. Therefore at a 100KHz cycling rate will last 277,777 hours continuous "ON" time for the scope which is 31 years continuous running @ 100KHz *even if the same memory address or row was used relentlessly at the 100KHz rate.*

**If a scope was run 8 hrs per 24 hr day and 5 days of a 7 day week, the 16w08 would be good for 130 years !**

The FM16w08 is commonly a 28 pin soic package so it needs to go on an adapter. This arrangement significantly out performs a DS1225Y in every way and once this is fitted the scope's memory troubles are over for good, for practical purposes at least. The following photo shows an FM16w08 mounted to a soic adapter acquired on Ebay from seller semisurplus:



(These adapters have thin 0.45 to 0.5mm diameter round gold plated pins – don't use thick square pin adapters as they damage the dual wipe IC socket. These adapters also work well in round machined pin sockets)

Other Frams running at 3.3V now have been attributed with a  $10^{15}$  cycle endurance and it would appear that the theoretical limit for the Fram endurance is in the order of  $10^{16}$  as the supply voltage is reduced to around 1.5V.

## B) THE AUTOSTORE nvRAM:

The STK12C68 is another 8k x 8 parallel type in a 28 pin soic package. This non-volatile ram incorporates a type of shadow memory and requires an external 100uF storage capacitor. At power down the data in the main Sram memory is transferred to the shadow non volatile memory (called a Quantum Trap with a  $10^6$  cycle endurance) enabled by the charge stored in the 100uF capacitor. At “turn on” the shadow memory writes back to the main Sram memory & restores it. So it behaves (emulates) a battery backed up Sram, but there is no battery. It does require the external 100uF capacitor and a 0.1uF bypass capacitor.

This uses some extra pcb area. Unlike the Fram that does not require this. Cypress bought out Simtek (who developed the STK12C68 Autostore IC), then later they bought out Ramtron who developed the FM16w08. Perhaps they could see that the FM16w08 ferroelectric ram technology might be the superior way to go and saved on these extra parts.

The following photo shows the required added parts on an adapter for the STK12C68 :

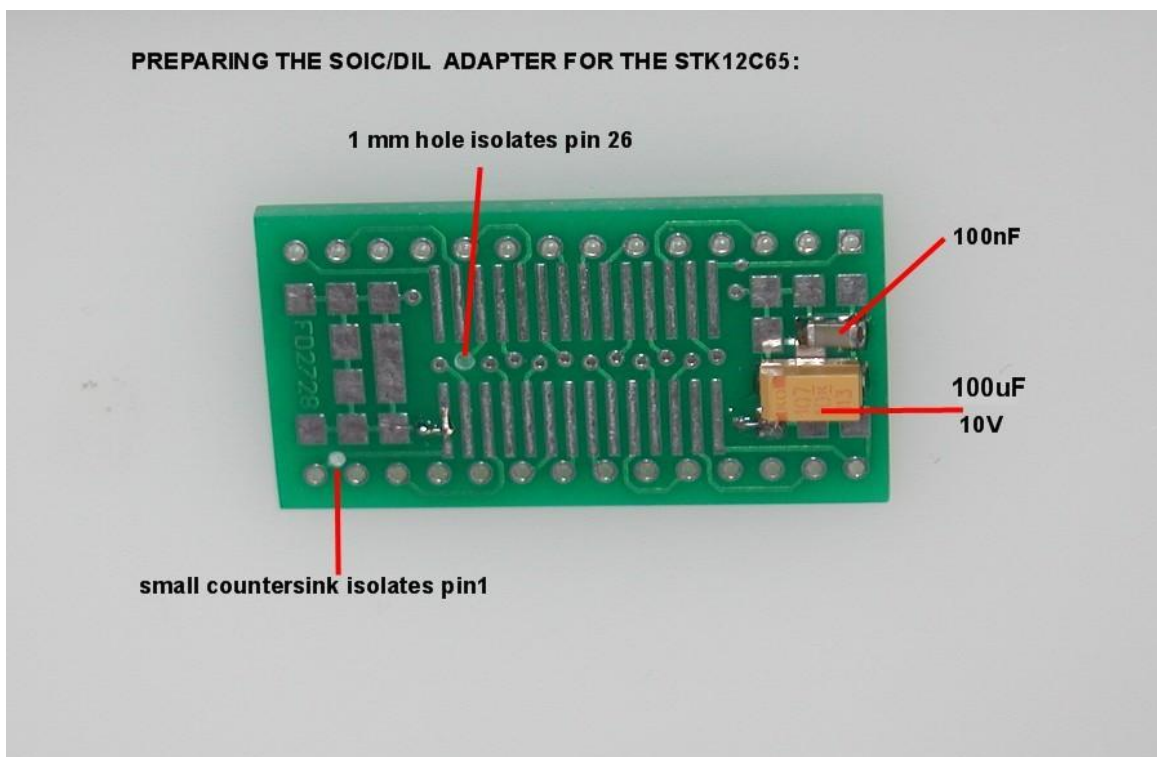

The photo below shows the underside of the adapter for the STK12C68. Pin 26 is left open circuit. It is important that pin 1 and pin 26 of this “DS1225” simulator are open circuit, just as they are in the DS1225. Also the capacitors connect to pin 1 of the actual IC:

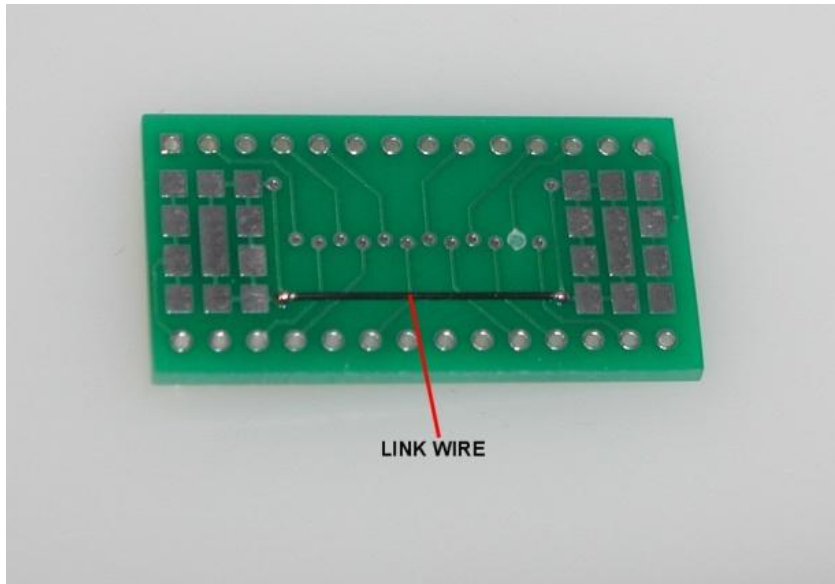

The photos below shows the finished item which works equally as well as the FM16w08 in the 2465b and again is a superior option to a DS1225:

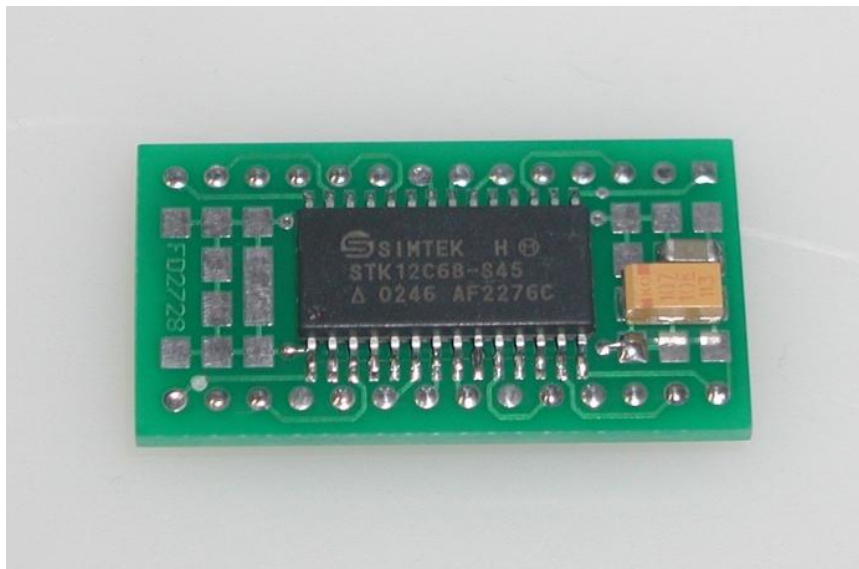

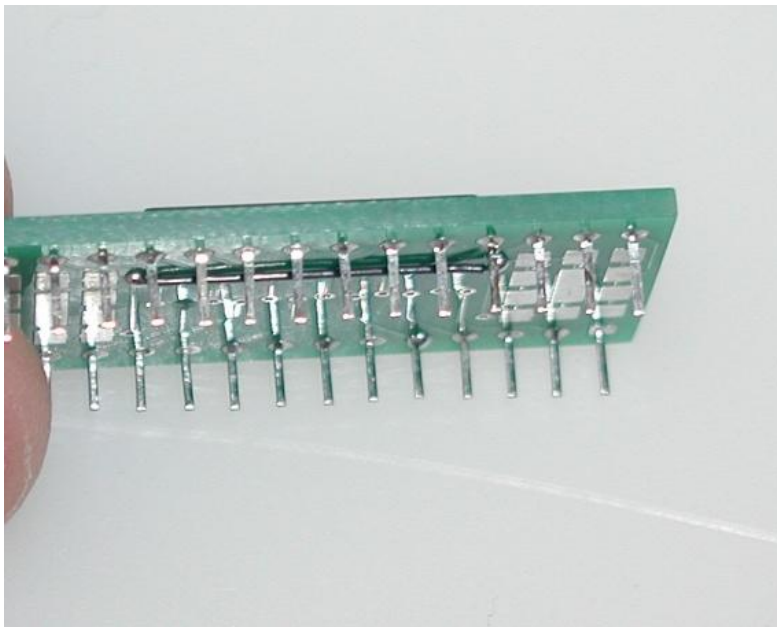

(Thin flat pins were added to this adapter board as shown in the photo above)

Whether to use the STK12C68 or the FM16w08 could be a matter of preference. Both are better than the DS1225Y in that the battery problem is eliminated. It would appear to be difficult to beat the genius of the FM1608 or FM16w08 Fram.

*There might have also been another choice too, if only history had allowed it for this particular application.....*

### **C) THE MAGNETORESISTIVE RAM:**

Another type of non volatile ram is Magneto-Resistive, or Mrams. Cypress were developing this technology around 2004 to 2005. They produced a preliminary data sheet on a CY9C6264 and the pdf datasheet for this item circulated the internet, often taken up by the search engines "Stocking Parts Supply Companies" some of whom claim to actually have it in stock. It was a byte-wide 8k x 8 non volatile memory IC in a SOIC 28 package. However it appears they were never mass produced or commercially shipped to suppliers at all because Cypress sold off their Mram technology. It seems that this IC would have been just as good as the FM16w08, if not even better if that were possible. Everspin took up manufacturing of Mrams, but unfortunately they do not appear to make an 8k x 8 product currently and their products are generally for 3.3V applications too.

**UPDATE: Using larger memories with “Page Select”:**

A 256Kb memory (32k x 8 bytes) has 4 times the capacity of an 8k x 8 memory and it has two higher order address lines, labeled A13 and A14 and the same 28 pin IC package. By connecting these to a BCD switch, the memory can be selected in four separate “pages”, pages 0, 1,2,3 as indicated on the switch.

Tek may have been considering using a larger sized memory in the 2465b, such as the DS1235 32k x 8 module which had 4 times the memory capacity as the DS1225 8k x 8 module, perhaps to store unique setting for individual operators. Despite the fact that the two higher order address pins, pin 1 (A14) and 26 (A13) of the DS1225 are N/C, inspection of the A5 schematic shows these are connected to the programmable logic memory address decoder IC U2250. These address lines, which are active when scoped, give a problematic result if a 256k memory is plugged in directly into the socket and produce parity & checksum errors unless the memory file from a single DS1225 is written into each of the four 8k x 8 “pages”. Even then the calibration and memory settings are affected. It would probably be ok if the scope was calibrated from scratch with 32k x 8 memory module but I’m not 100% sure about this.

One interesting alternative is to use the larger memory IC on an adapter board leaving pins 1 and 26 N/C (as they are for a 8K x 8 memory the scope was designed with) and have a page selector switch on the adaptor. This means that there is one page of memory mimicking the DS1225, and three duplicates available. The three duplicate copies are not exercised at all and never addressed and have 45 year data retention at least for the FM18w08. In the event of any memory corruption, the page selector switch can be turned and the memory is now as it was when the scope was calibrated. It is like having a permanent memory restore function. This arrangement is shown below:

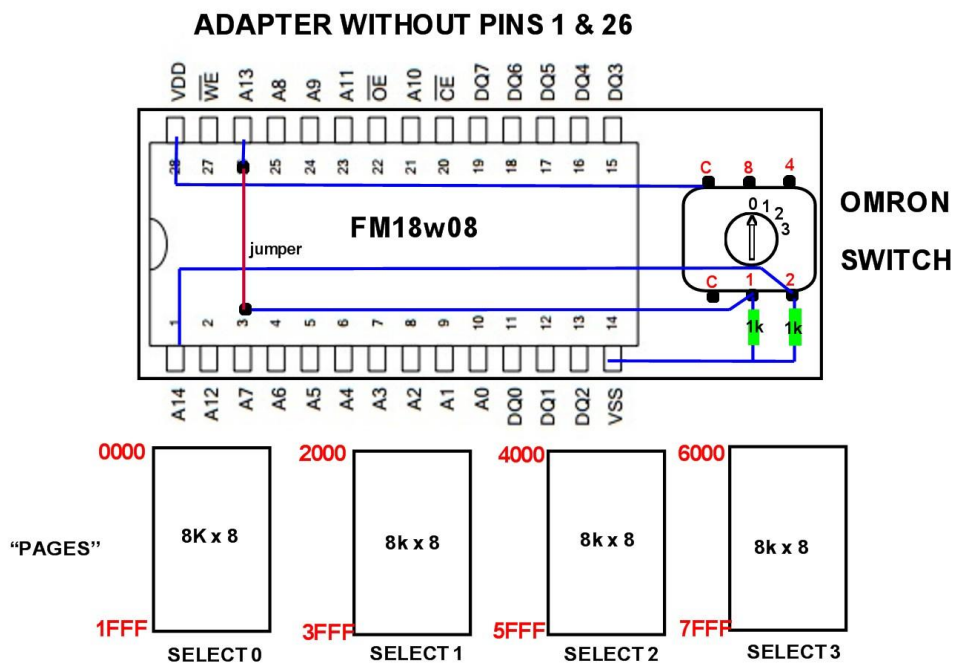

This item is placed in the programmer set for DS1225 and programmed for each of the 4 switch positions so that there are 4 replica programs placed in it. Page 3 could be reserved for writing in ID and calibration date information, as two spare pages/memory copies would be more than enough.

The photos below show the adapter was made. It needs to be low profile and no thicker than a DS122 module when the IC is plugged in. The long thin gold pins were taken from the adapters supplied by semisurplus. These are pressed out with a 0.4mm pin. They are thin enough that they can reside in a plated through hole along with the pin from the IC socket. The photos show the rest of the story:

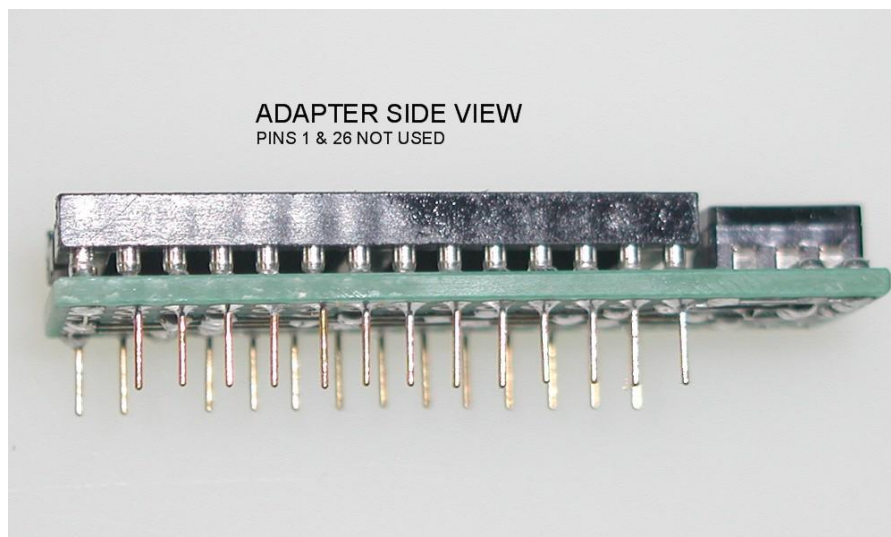
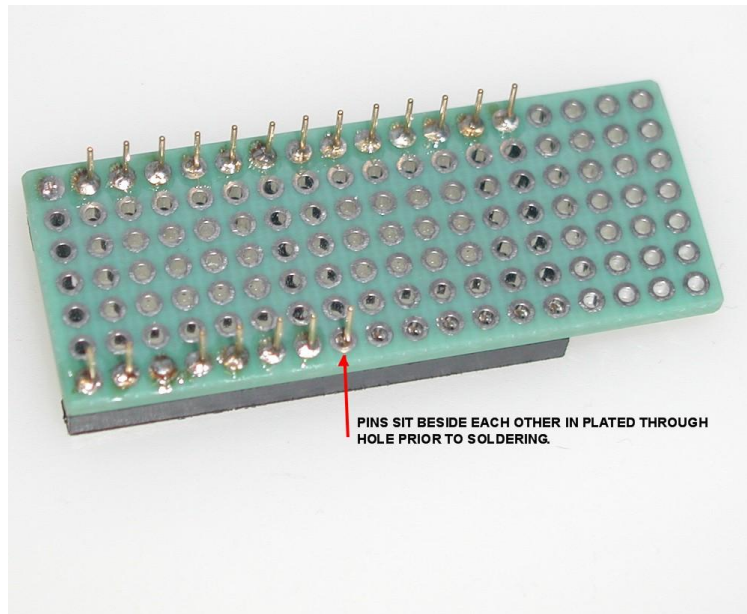

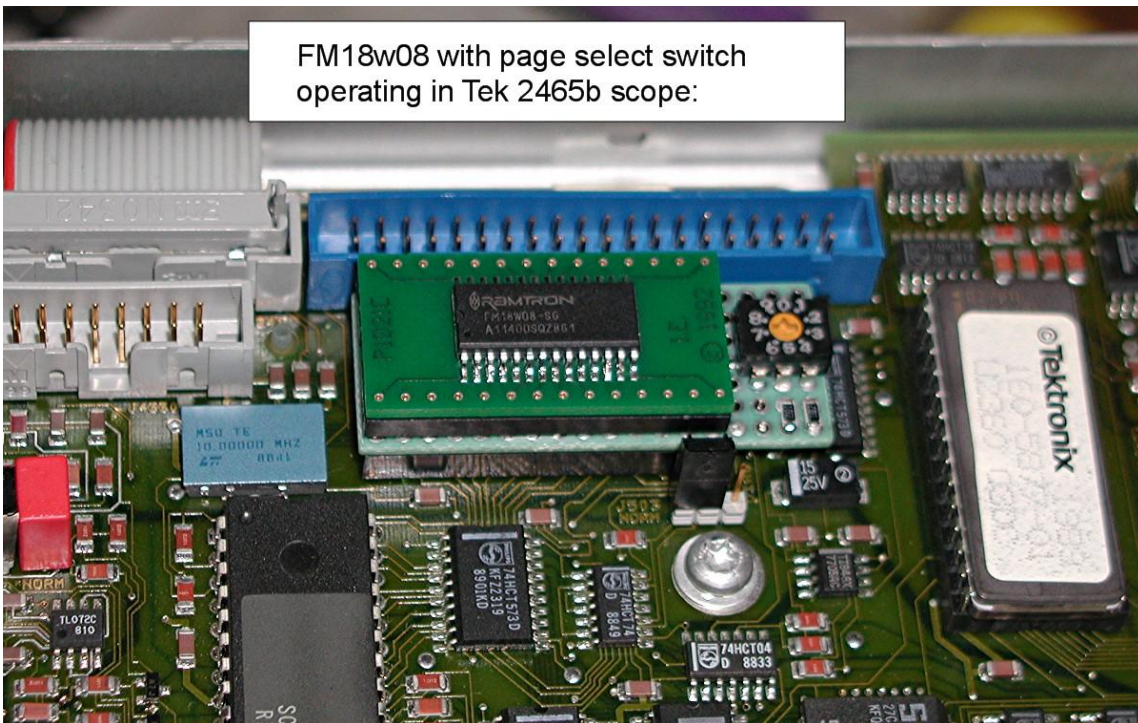
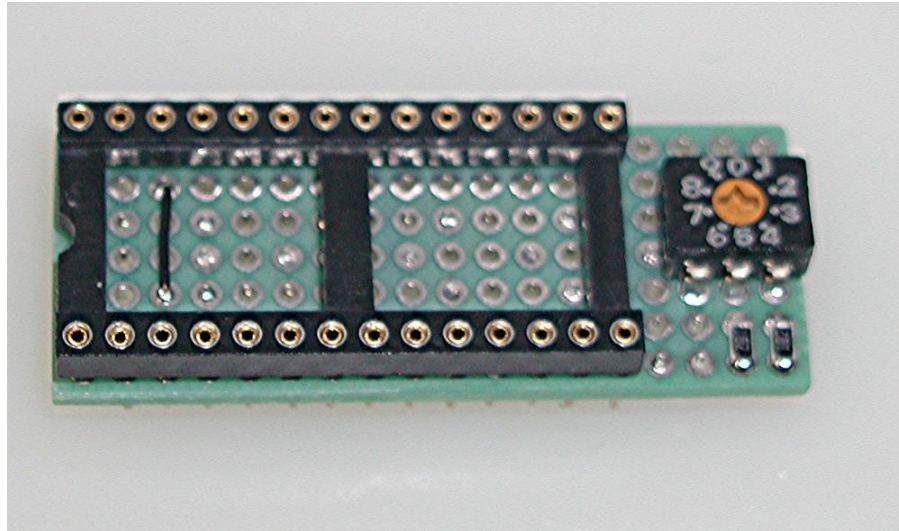

The adapter above was made so that the DIP versions of the FM18w08 or the SOIC versions on their own adapter could be used. The DIP versions of the FM18w08 are still available (on the other hand the DIP versions of the FM16w08 are rare). Obviously a custom SOIC adapter could be made with pins 1 & 26 missing and the BCD switch mounted directly on that.

## INSTRUMENTS FOR CALIBRATING THE 2465b:

The generator instruments (plug ins) required for this are primarily the TEK PG506 calibration generator to set the vertical calibration and the TG501 Time marker generator for the horizontal system or time-base.

*Other generic generators cannot be used as easily as Tek designed the 2465b software protocol specifically for these units.*

One other generator is a handy luxury, not absolutely required, but good for checking the vertical bandwidth, is the SG503 leveled sine wave generator plug in. The photo below shows the two essential Tek plug ins on the Right hand side:



Also in the unit above, on the left hand side, is a custom (home made) plug in module which brings the edge connector from the rear of the TM503 power unit to the front panel and has indicator LED's which monitor the condition of the power rails to make sure they are in spec. This is useful for repairing "plug ins" themselves, when they need it. An extension cable can be used between this edge connector and the plug in unit undergoing repairs.



Extension cable for plug in servicing if it is needed:

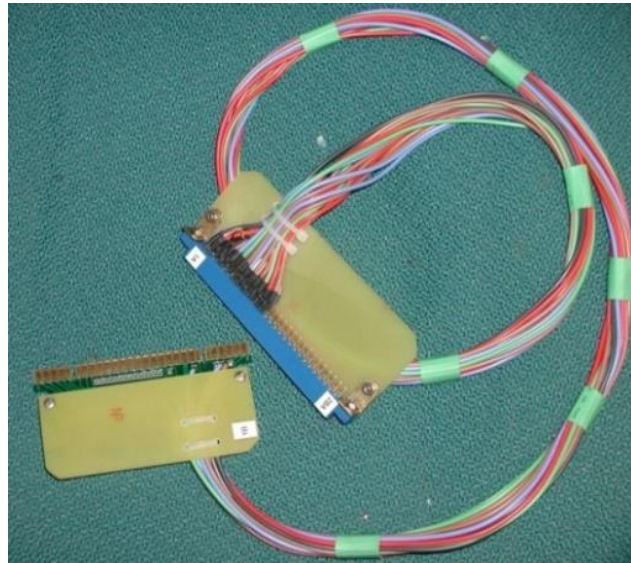

Other items required for 2465b calibration are a Tunnel Diode Pulser to help generate a fast rise rectangular edge waveform. If the tunnel diode pulser (Tek part 067-0681-01) is not available the PG506 on its own is satisfactory to produce a good rectangular test waveform from its -1V to 0V fast rise output, but not quite as good as the tunnel diode pulser.

A **Tunnel Diode Pulser** has the general configuration shown below:

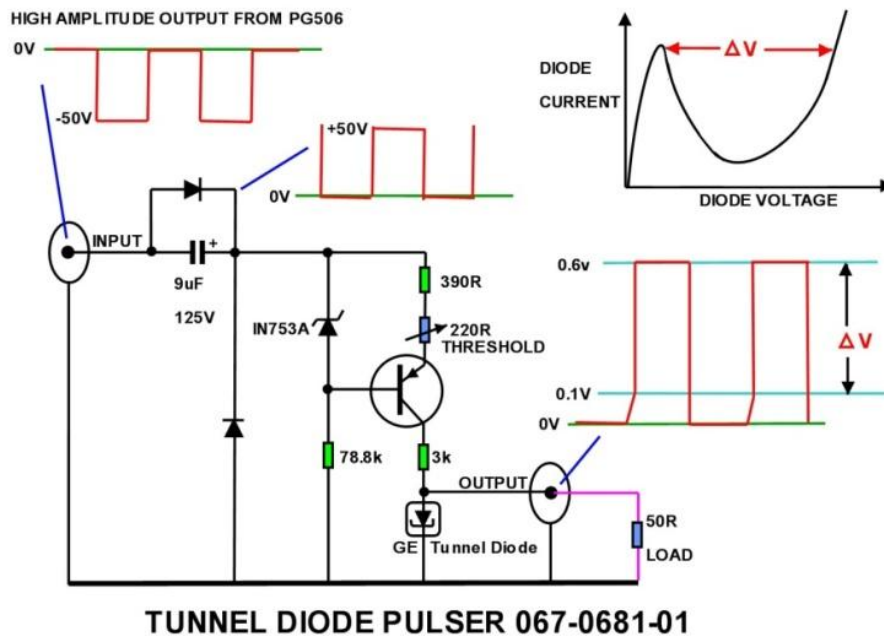

Once the voltage applied to the Tunnel diode reaches a threshold, around about 100mV, the diode moves into it negative resistance region and electron tunneling begins. There is a sudden (almost instantaneous) voltage step  $\Delta V$  as the current attains a new stable state. This rapid voltage transient is only limited by the Tunnel diode's small junction capacitance and its peak current rating. The waveform also has a perfectly flat top.

The square edge waveform produced by the Tunnel Diode Pulsar is perfect for checking the fidelity of oscilloscope vertical amplifiers. The input arrangement on this pulser allows for the pulser to work with either positive or negative going square wave inputs. The PG506 high amplitude output produces a negative going square wave, the 9uF input capacitor AC couples this and the diodes DC restore it to a positive going wave as shown in the diagram above.

Also a series of passive attenuators are required for the scope calibration (see below how to make these attenuators if you don't have original Tek ones).

It is a moderately time consuming business to fully calibrate the 2465b. It takes about one to two hrs and familiarity with the manual and the protocol. As well as the Tek generators required, a good BNC to BNC 50 Ohm cable and some 50 Ohm attenuators are required, a x2, x2.5, x5 and x10 attenuator. I made these myself using the body of a standard BNC- BNC housing ( Jaycar Attenuator part LT3057) opening it up, putting in the correct resistors and soldering it up again as shown in the photo's:

DONOR BNC-BNC housing:



After the correct resistors were placed inside, the units were soldered back together and labeled. This was cheaper than buying pre made Tektronix attenuators:



These attenuators are simply 50 Ohm terminators which terminate a signal in a 50 Ohm load and drop the generator signal down by a factor of 2, 2.5, 5 or 10. In this case they are operating in a 50 Ohm system and they have a 50 Ohm impedance looking into their input or output, when the other terminal is terminated by 50 Ohms. If they are not terminated the scale factor and the impedance match will be incorrect. The input and output resistors R1 are identical.

The following formulae show how to calculate the resistors:

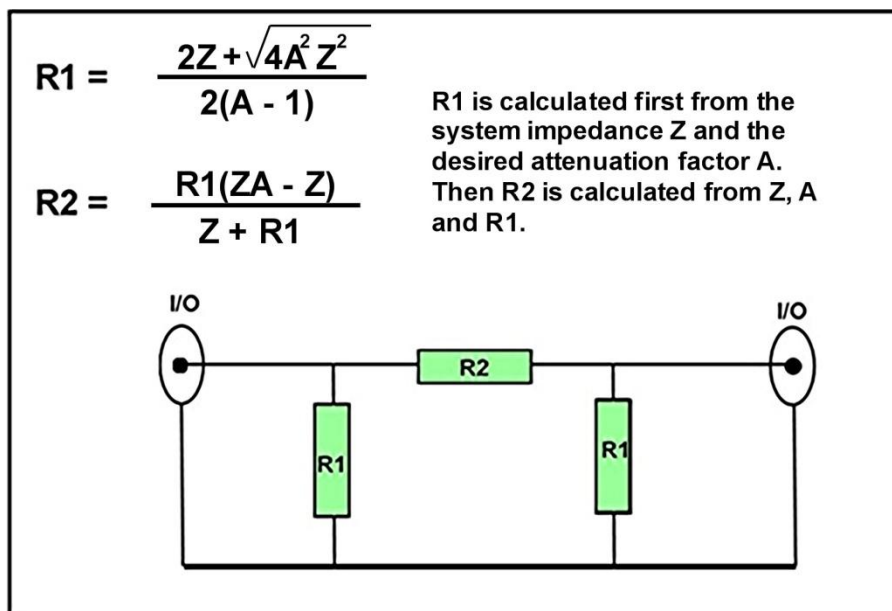

So for example using the formulae in the table above, the “x2” attenuator has R1 values of 150 Ohms and an R2 value of 37.5 Ohms. Or a “x10” attenuator has R1 values of 61.11 Ohms and an R2 value of 247.49 Ohms for example. These resistors can be made by using series or parallel combinations of standard resistors to approximate the value as closely as possible.

**Notes on performing the 2465b calibration:**

As usual when performing a calibration the instructions in the service manual should be faithfully followed. However I believe there is an error of omission in the calibration instructions for the vertical amplifier section. This omission can result in up to a 1.7% vertical deflection calibration error, depending on the particular scope, if not corrected. While this appears to be a small error amount it is better avoided. The variability of this error between scopes appears to relate to the exact position of the CH1 VAR control, which for a 10 division trace (see below) is in a slightly different position on different scopes.

The CAL-02 instructions page 5-17 in the manual states;

Step g: Adjust CH1 position and volts/div VAR controls to obtain a 10 division horizontal signal. Press & release the upper trigger coupling switch. Then steps 111 & 112 are automatically done. Then the protocol goes directly to step 113. However, the missing instruction prior to the technician continuing at step 113, I believe, should be:

**“RETURN VOLTS/DIV VAR CONTROL CH1 BACK TO DETENT POSITION BEFORE STARTING STEP 113”**

When Channel 2 is calibrated on steps 123 to 130, there is no need to do this because the CH2 volts/div VAR control is already (should be) in the detent position for channel 2.

If there is any doubt about this the vertical calibration can be done both ways and the accuracy of the vertical screen display & cursors can be checked out of calibration mode with the PG506 after the vertical calibration is complete. However, for my three 2465b’s, this was the only method which ensured accurate vertical calibration on all three of them.

\*\*\*\*\*